



## Cost Effective Programmable Vessel Control



- |                          |                |
|--------------------------|----------------|
| Remote Control           | Convenience    |
| Programmable Scenes      | Easy Operation |
| Reduced Cabling          | Energy Savings |
| User Programmable        | No PC Required |
| Open System Architecture |                |

Integration Of Audio/Video & Entertainment Systems  
Along With Electrical & Electronic Controls & Security Systems.



**The Vimar By-Me System Has Been Fully Tested And Purpose-Built-For The Marine Environment. Vimar Has Established A Worldwide Reputation For Excellence In Marine Switching And Control Systems.**

## BY – ME MARINE

Vessel Control At Your Command From Any Location Aboard.  
It Is Now Possible To Command Individual Or Group Functions Through Vimar Automated System Controls

### REMOTE CONTROLS

The Vimar Multi-Function Control Is A Fully Programmable Command System.  
Activation Via Infrared remote, Motion Sensors, Switches, Cellular Phone: You Decide.

### PROGRAMMED SCENES

Individual Or Group Functions Are At Your Command.  
Evening Comes And One Switch Or Remote Signal Can Change Any Group Of Programmed Functions.  
Lights, Motorized Curtains/Blinds, Day To Night Running, Audio / Video Or Security Functions , All At Your Command.

### CHOOSE YOUR VIMAR STYLE

Choose Between The Idea And Eikon Series,  
The Standard For Style And Design For Marine Switching Worldwide.  
Idea Coverplates: Classica – Square Edge / Rondo – Rounded Edge  
Switches In Grey Or White.  
Eikon Coverplates: Classica – Square Edge / Rondo – Rounded Edge  
Switches In Grey, White or Silver.

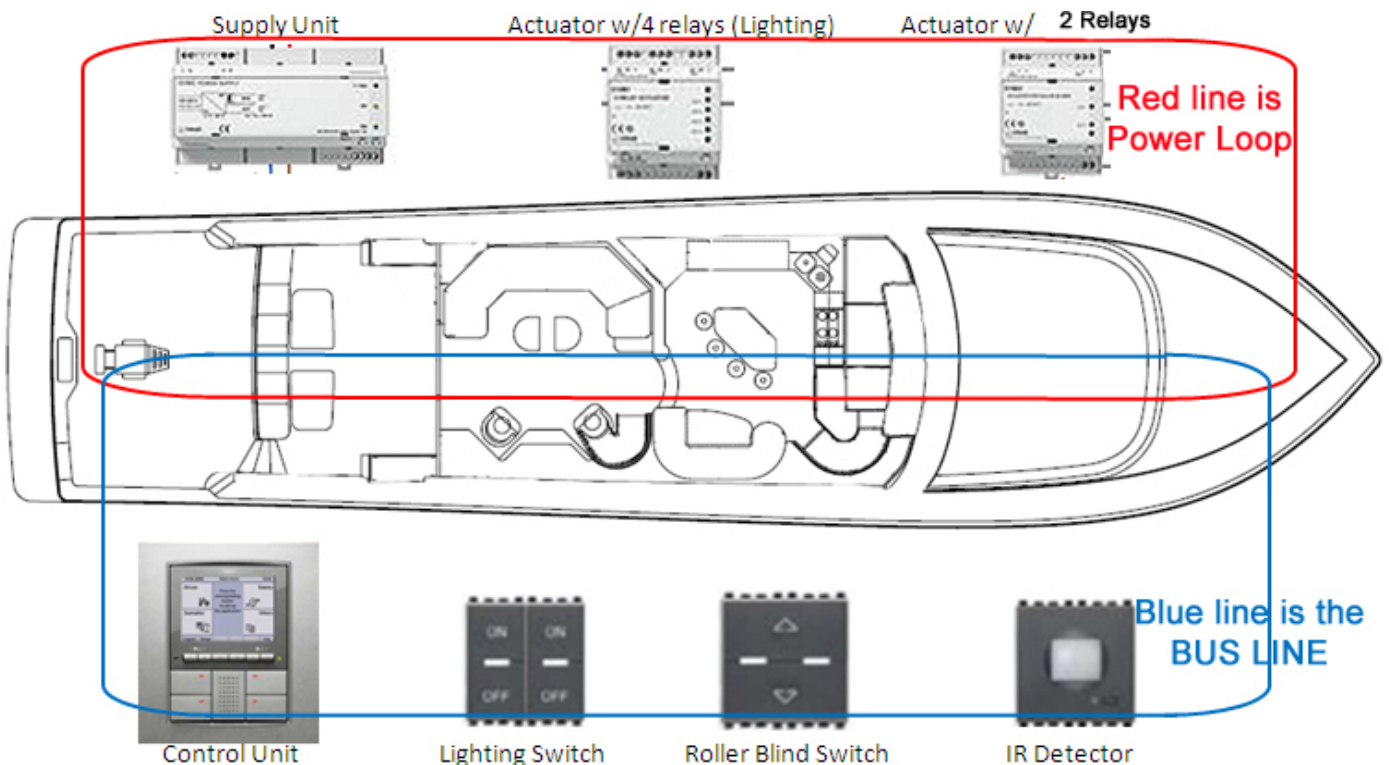

## TYPICAL BUSS / POWER SCHEMATIC

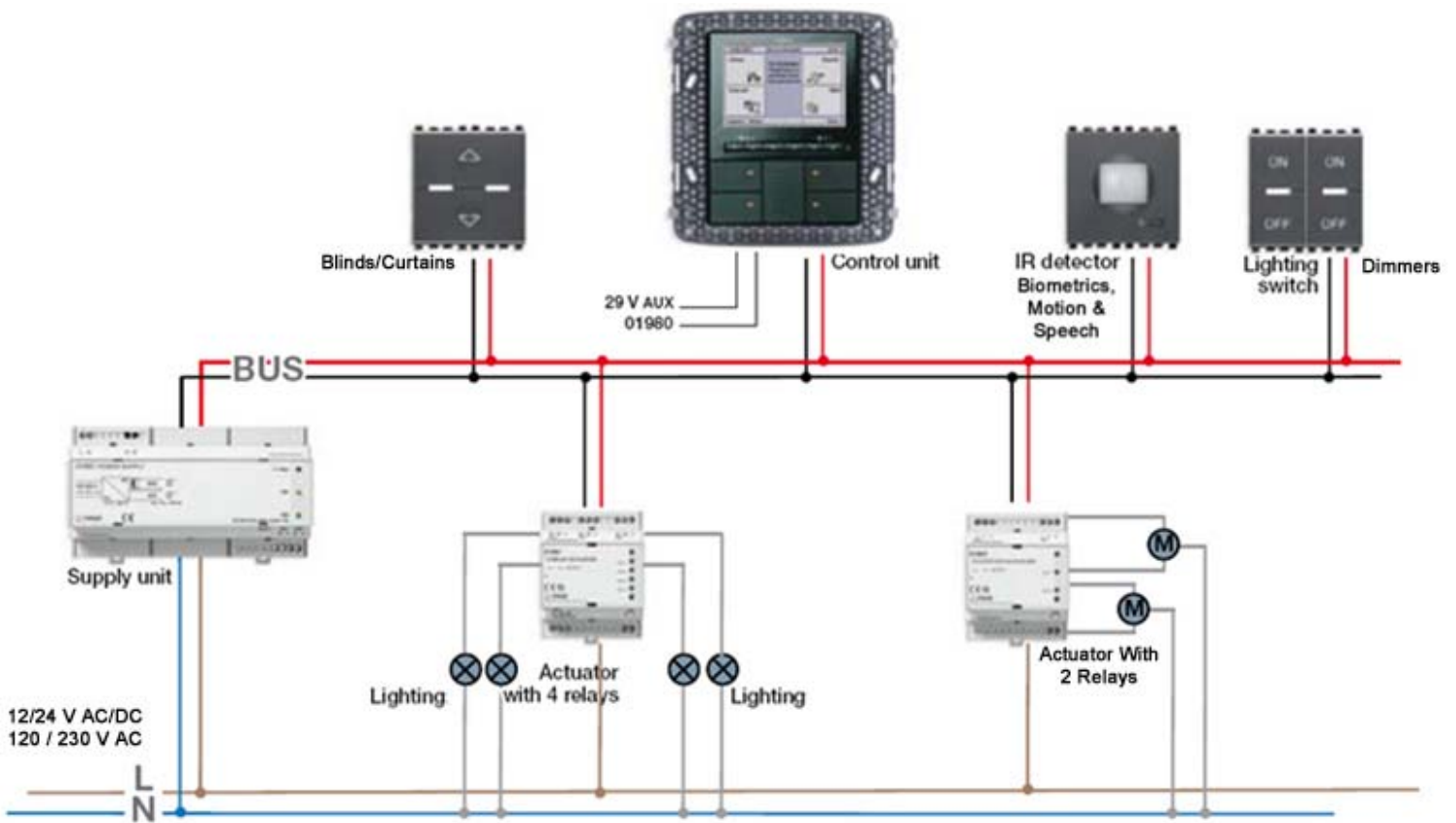

The **By-Me System** uses a simple twisted pair shielded cable as the BUS, carrying communications and power connection to tie all system components together.

**Access To the Control System** – can be accomplished through multiple technologies; biometrics, smart cards, phone, switches, infrared remote, voice or motion sensors among others.



Video Door Entry Unit



Speakerphone



Video Camera



Inner-Light



Call Button

**SEE MORE** - online at [www.drsa.com](http://www.drsa.com) or you can request a complete **By-Me Marine** Catalog.

## What is By-Me Marine?

For some it may be something as simple as remote or automatic control of a few lights. For others, security may be the central application. Still others may choose to install advanced controllers or use voice recognition. As a very basic definition, we tend to refer to the **By-Me Marine** system as anything that gives you remote or automatic control of systems aboard your vessel. The **By-Me Marine System** integrates all of the basic functions of electrical and electronic systems in a simple and effective manner.

With the programmable infrared multi-function remote control you can manage functions.

Infrared Receiver w/Remote



Automation Control Panel

This is the heart of the system, all functions are managed and programmed from here by navigating through the display in a straight forward user-friendly manner.



By-Me Manages

Lights and automation controls. Groups of lights and groups of motorized devices are controlled from here.



Idea - Rondo



Eikon - Rondo



Idea - Classica



Many other colors and options available.



Leaders In Marine Lighting & Electrical Products

7950 Central Industrial Drive Suite 106, Riviera Beach, FL 33404  
Ph. 561-842-5704 / 800-844-8593, Fax 561-842-5705 [www.drsa.com](http://www.drsa.com)